

Printed By: Dominique Print Date: June 3, 2024 Filename: N:\0101008\3\CADD\Phase 3\Parcel 19\DS.P19\FPLAT.01-02.dwg

LOT AREA TABLE with columns for Lot # and Area (Square Feet), listing lots 1 through 60.

LOT AREA TABLE with columns for Lot # and Area (Square Feet), listing lots 61 through 119.

CURVE TABLE with columns for NO., LENGTH, RADIUS, DELTA, TANGENT, CHORD, and CHORD-BEARING, listing curves C1 through C45.

TRACT TABLE with columns for Tract, Area, and Description, listing tracts A through M and a total.

LINE TABLE with columns for NO., BEARING, and LENGTH, listing lines L1 through L10.

CITY OF MARICOPA NOTES containing 8 numbered points regarding utility easements, construction restrictions, and property maintenance.

LAND USE TABLE with columns for Land Use Areas, Square Feet, and Acres, listing lots, right of way, and tracts.

TOTAL LAND USE table listing total number of lots (119), total number of tracts (13), and gross residential density (4.5 D.U./A.C.).

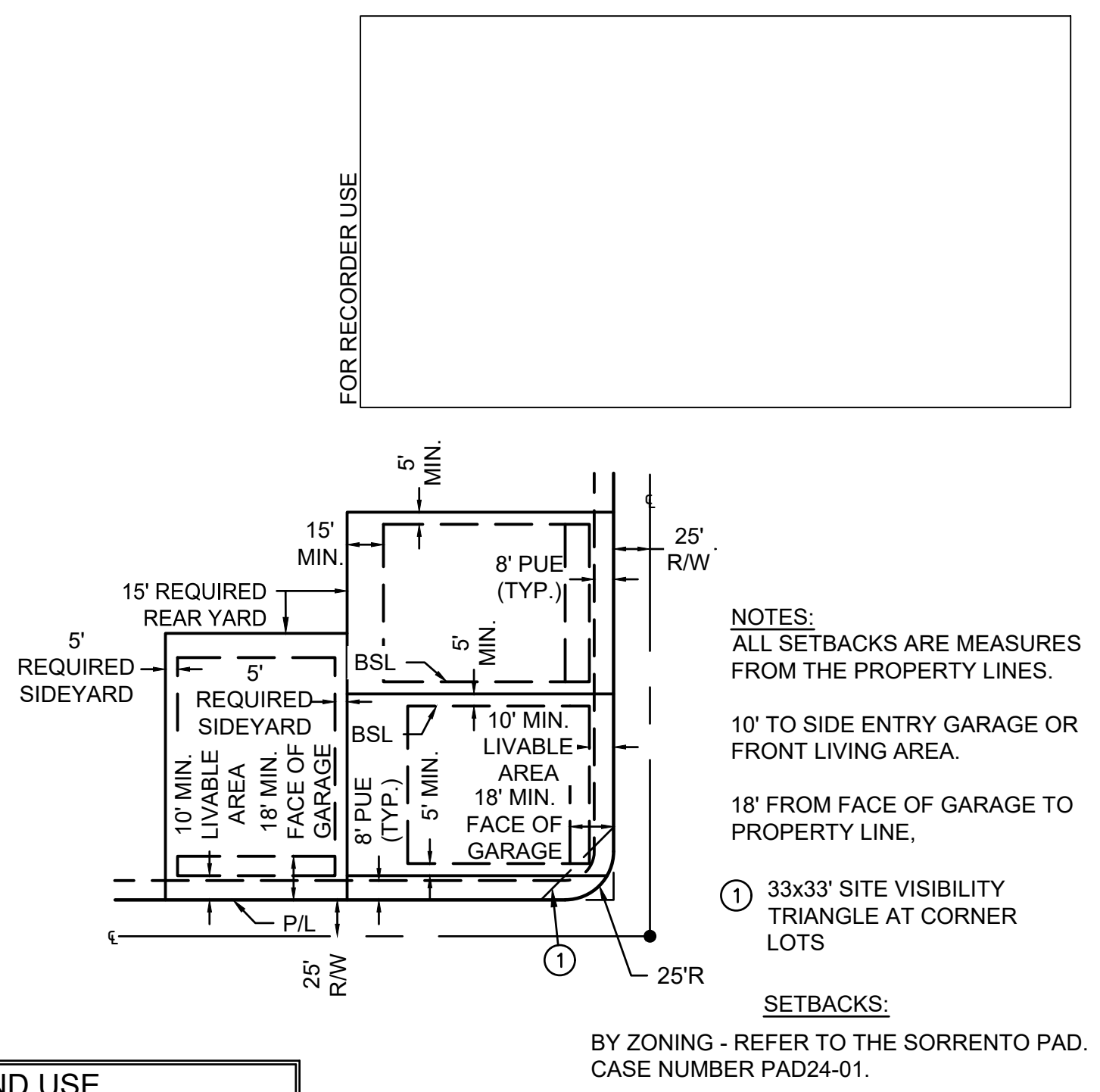

TYPICAL LOT LAYOUT AND BUILDING SETBACKS N.T.S.

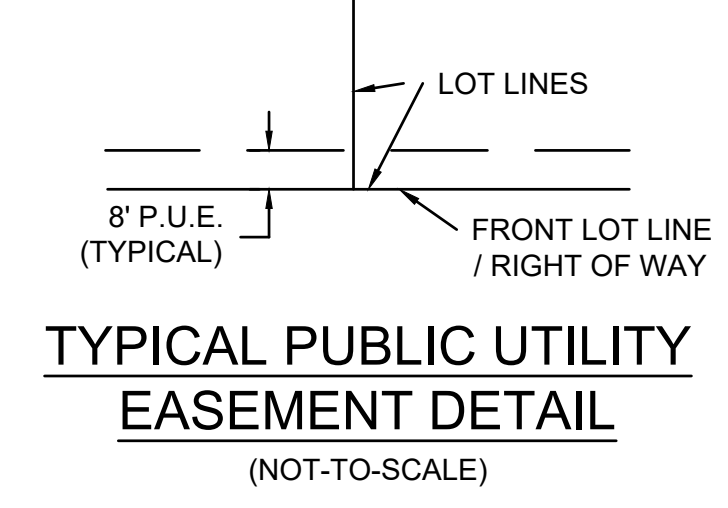

TYPICAL PUBLIC UTILITY EASEMENT DETAIL (NOT-TO-SCALE)

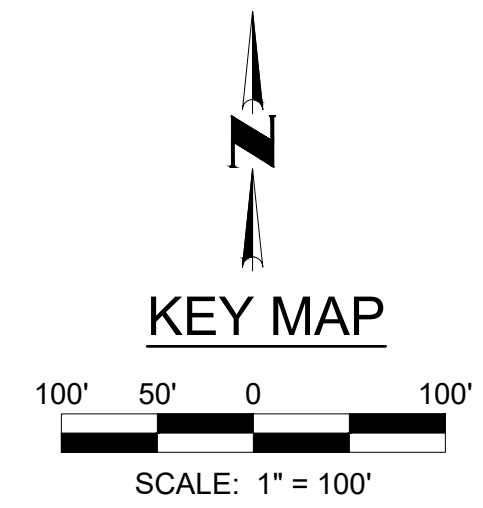
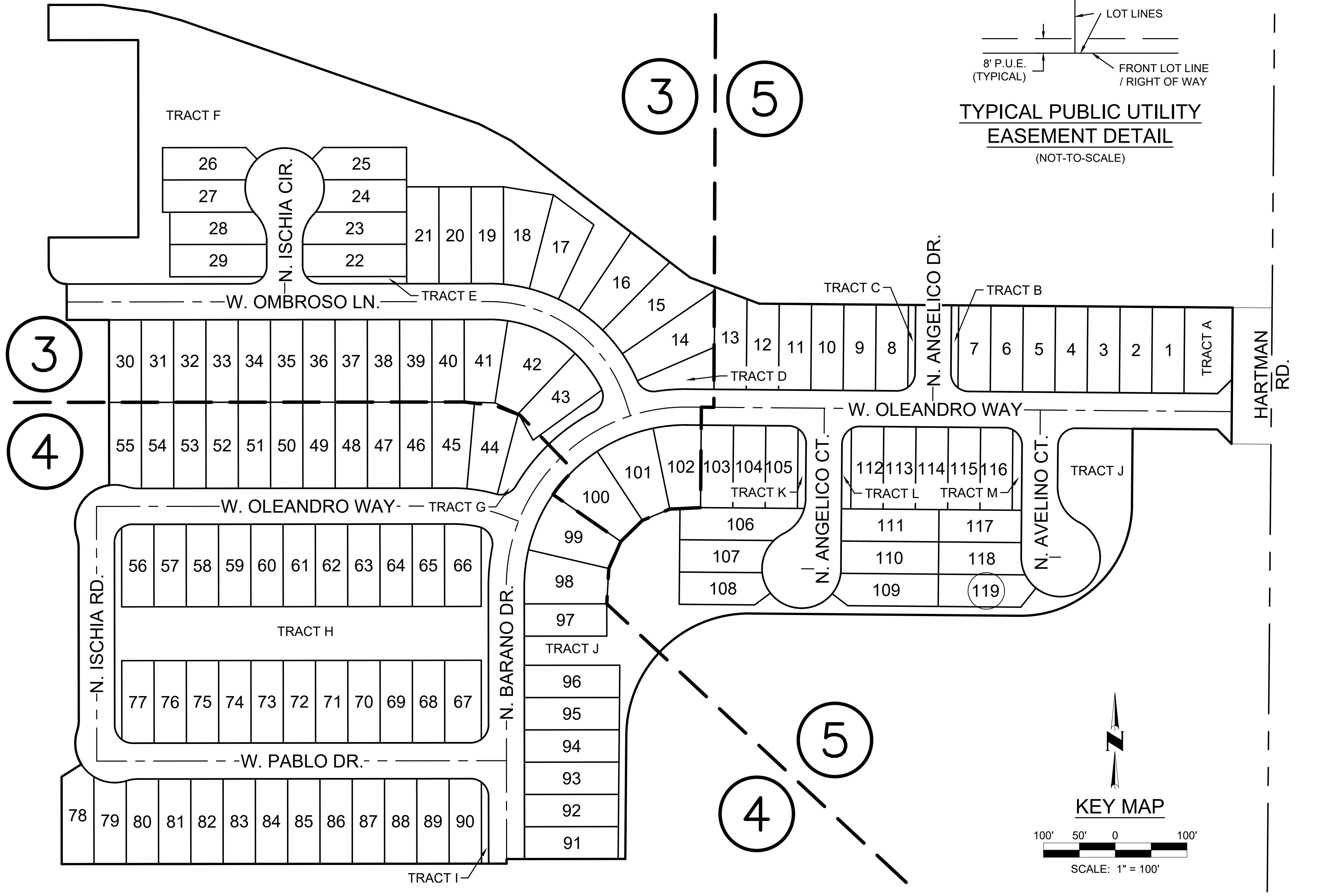

DATE: REVISION: NO. COE & VAN LOO CONSULTANTS, INC.

FINAL PLAT SORRENTO PHASE 3 - PARCEL 19 CITY OF MARICOPA, ARIZONA

Registered Land Surveyor CERTIFICATE NO. 33851 RICHARD G. ALCOCKER 06/28/2024 PROJECT NO. 01-01008 2 SHEET OF 5 SEE SHEET 2 FOR CURVE, LINE, TRACT AND LOT AREA TABLE

NO.	REVISION	DATE

FINAL PLAT
SORRENTO PHASE 3 - PARCEL 19
 CITY OF MARICOPA, ARIZONA

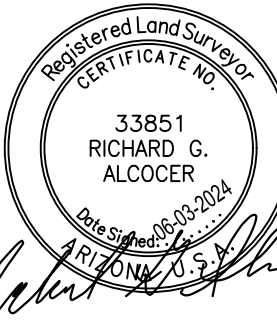
 3 SHEET OF 5
 CVL Contact: D. CHUBIN
 CVL Project #: 01-01008
 © 2022 Coe & Van Loo Consultants, Inc.
 All rights reserved to reproduction in any format

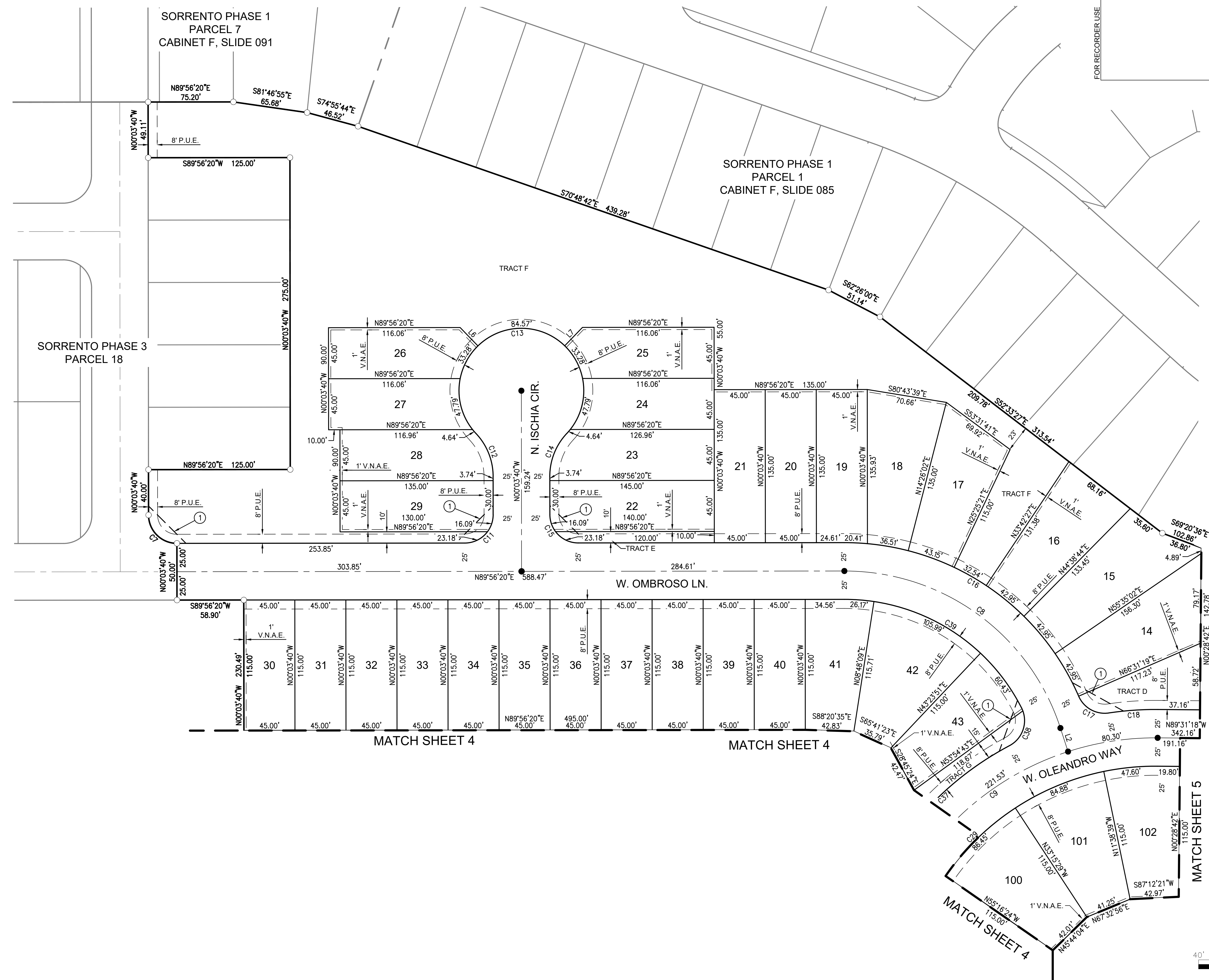

SORRENTO
PHASE 3
PARCEL 18

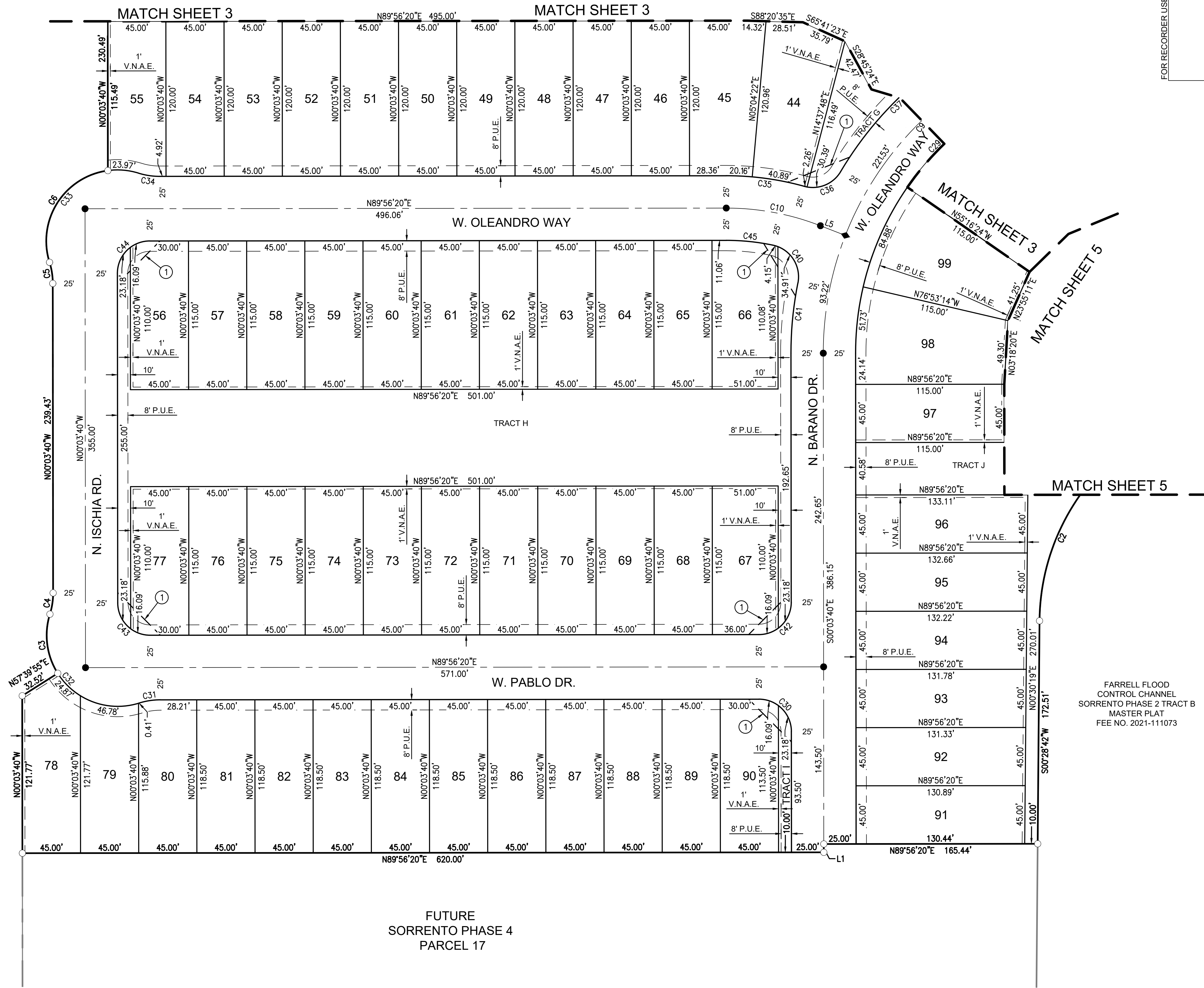

FOR RECORDER USE

NO.	REVISION	DATE

FINAL PLAT
SORRENTO PHASE 3 - PARCEL 19
 CITY OF MARICOPA, ARIZONA

Registered Land Surveyor
 CERTIFICATE NO. 33851
 RICHARD G. ALCOCKER
 06/03/2024
 06/03/2024

4 SHEET OF 5

CVL Contact: D. CHUBIN
 CVL Project #: 01-01008

© 2022 Coe & Van Loo Consultants, Inc.
 All rights reserved for reproduction in any format

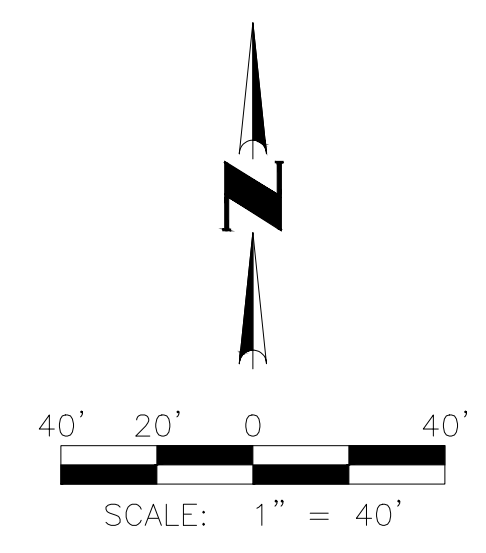

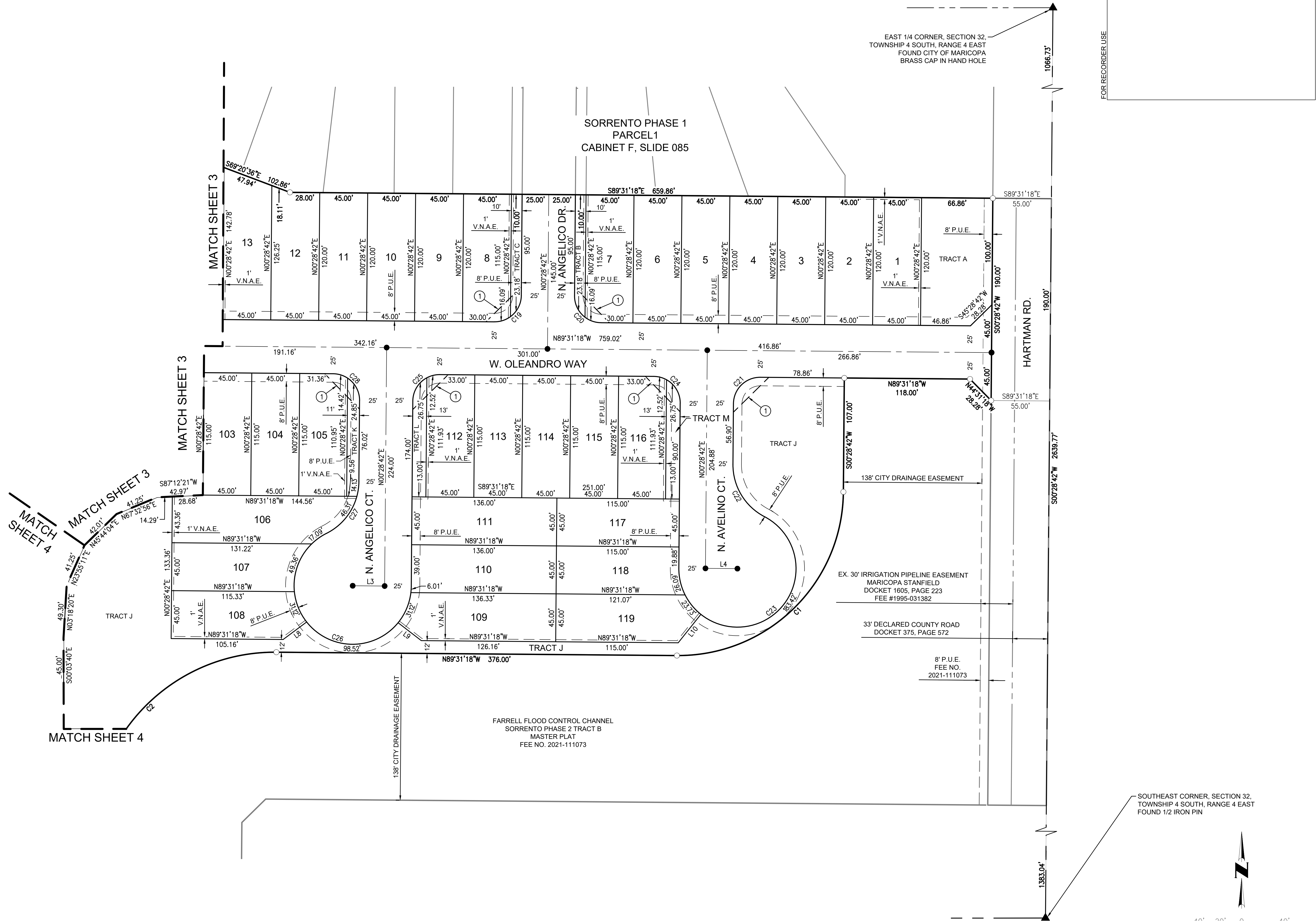

EAST 1/4 CORNER, SECTION 32,
TOWNSHIP 4 SOUTH, RANGE 4 EAST
FOUND CITY OF MARICOPA
BRASS CAP IN HAND HOLE

FOR RECORDER USE

NO.	REVISION	DATE

FINAL PLAT
SORRENTO PHASE 3 - PARCEL 19
CITY OF MARICOPA, ARIZONA

Registered Land Surveyor
CERTIFICATE NO. 33851
RICHARD G. ALCOCKER
Arizona State Board of Registration for Professional Engineers and Surveyors
2022-2026

5 SHEET OF 5
CVL Contact: D. CHUBIN
CVL Project #: 01-01008
© 2022 Coe & Van Loo Consultants, Inc.
All rights reserved for reproduction in any format

