

FINAL PLAT
FOR
MARICOPA CITY COMPLEX
A RE-PLAT OF LOT 4 OF "BLOCK PLAT FOR CITY OF MARICOPA COMPLEX"
FEE 2023-XXXXXX PCR

LOCATED IN A PORTION OF THE SOUTHWEST QUARTER OF SECTION 30, TOWNSHIP 4 SOUTH, RANGE 4 EAST
OF THE GILA AND SALT RIVER MERIDIAN, PINAL COUNTY, ARIZONA

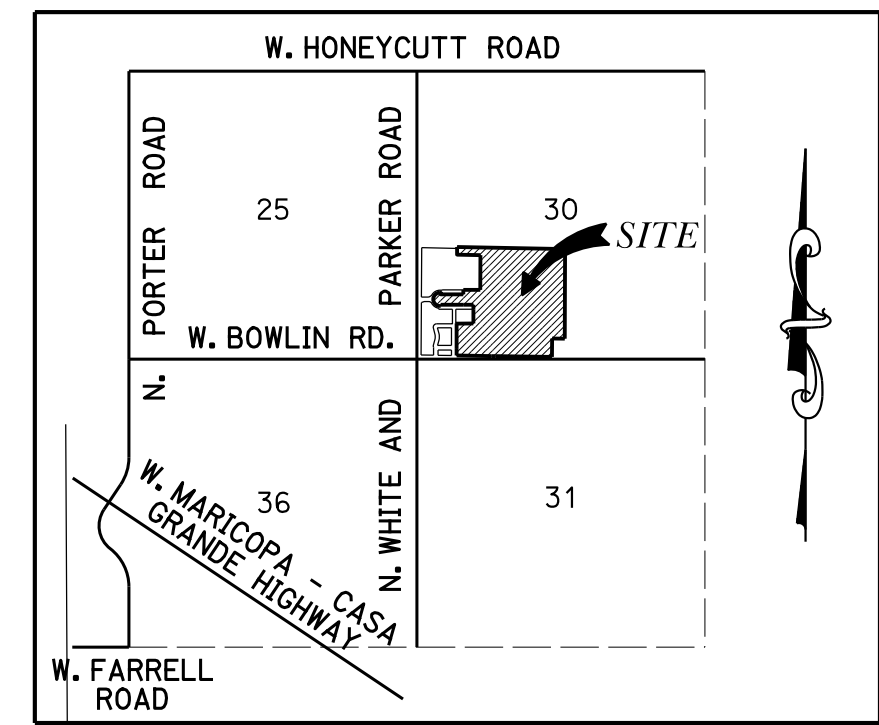

VICINITY MAP
N.T.S.

DEDICATION:

STATE OF ARIZONA }
COUNTY OF PINAL } SS

KNOW ALL MEN BY THESE PRESENTS:

THAT THE CITY OF MARICOPA, A MUNICIPAL CORPORATION, AS OWNER DOES HEREBY PUBLISH THIS FINAL PLAT FOR "MARICOPA CITY COMPLEX" OVER A PORTION OF SECTION 30, TOWNSHIP 4 SOUTH, RANGE 4 EAST OF THE GILA AND SALT RIVER MERIDIAN, PINAL COUNTY, ARIZONA, AS SHOWN AND PLATTED HEREON AND HEREBY PUBLISHES THIS PLAT AS, AND FOR, THE PLAT OF SAID "MARICOPA CITY COMPLEX" AND HEREBY DECLARES THAT SAID PLAT SETS FORTH THE LOCATION AND GIVES THE DIMENSIONS OF THE LOTS, STREETS, AND EASEMENTS CONSTITUTING SAME, AND THAT EACH LOT, STREET, AND EASEMENT SHALL BE KNOWN BY THE NUMBER, LETTER OR NAME GIVEN TO EACH RESPECTIVELY ON SAID PLAT.

THE CITY OF MARICOPA, A MUNICIPAL CORPORATION, IS THE OWNER OF FEE TITLE TO THE FOLLOWING PROPERTY, AND IS THE ONLY PARTY HAVING AN INTEREST IN THE FOLLOWING PROPERTY: (A) THE PROPERTY BEING DEDICATED ON THE MAP FOR ROADWAY PURPOSES.

THE CITY OF MARICOPA, A MUNICIPAL CORPORATION, AS IOWNER HEREBY DEDICATES A 70 FOOT WIDE RIGHT-OF-WAY FOR PARK PLAZA.

IN WITNESS WHEREOF: THE CITY OF MARICOPA, A MUNICIPAL CORPORATION, AS OWNER, HAS HEREUNDER CAUSED ITS NAME TO BE AFFIXED AND HAS EXECUTED THIS SUBDIVISION PLAT BY THE SIGNATURE OF THE UNDERSIGNED DULY AUTHORIZED THIS ____ DAY OF _____, 20 ____.

OWNER: THE CITY OF MARICOPA, A MUNICIPAL CORPORATION

BY: _____

ITS: AUTHORIZED REPRESENTATIVE

ACKNOWLEDGEMENT:

STATE OF ARIZONA }
COUNTY OF PINAL } SS

ON THIS ____ DAY OF _____, 20 ____ , BEFORE ME, THE UNDERSIGNED, PERSONALLY APPEARED _____, WHO

ACKNOWLEDGED SELF TO BE THE PERSON WHOSE NAME IS SUBSCRIBED TO THE INSTRUMENT WITHIN, AND WHO EXECUTED THE FOREGOING INSTRUMENT FOR THE PURPOSES THEREIN CONTAINED.

IN WITNESS THEREOF, I HEREUNTO SET MY HAND AND OFFICIAL SEAL.

BY: _____ NOTARY PUBLIC MY COMMISSION EXPIRES _____

MY COMMISSION EXPIRES: _____, 20 ____

LEGAL DESCRIPTION:

THE LAND REFERRED TO HEREIN BELOW IS SITUATED IN THE COUNTY OF PINAL, STATE OF ARIZONA, AND IS DESCRIBED AS FOLLOWS:

LOT 4 OF 'BLOCK PLAT FOR CITY OF MARICOPA COMPLEX', ACCORDING TO THE PLAT OF RECORD IN THE OFFICE OF THE COUNTY RECORDER OF PINAL COUNTY, ARIZONA, RECORDED IN RECORDING NO. XXXXXXXX.

RECORD DOCUMENTS:

(R) RE-PLAT OF LOT 4 OF 'BLOCK PLAT FOR CITY OF MARICOPA COMPLEX' AS RECORDED PER FEE NO. XXXXXXXXX P.C.R.

REFERENCE DOCUMENTS:

FEE NO. 2020-13909 P.C.R.
FEE NO. 2019-030804 P.C.R.
FEE NO. 2013-075289 P.C.R.
FEE NO. 2013-000598 P.C.R.
FEE NO. 2010-093892 P.C.R.
FEE NO. 2022-115633 P.C.R.

AREA:

OVERALL GROSS AREA: 3,338,705 SQUARE FEET OR 76.646 ACRES

LOT 4A NET AREA: 99,922 SQUARE FEET OR 2.293 ACRES
LOT 4B NET AREA: 150,870 SQUARE FEET OR 3.463 ACRES
LOT 4C NET AREA: 129,597 SQUARE FEET OR 2.975 ACRES
LOT 4D NET AREA: 279,131 SQUARE FEET OR 6.408 ACRES
LOT 4E NET AREA: 36,713 SQUARE FEET OR 0.842 ACRES
LOT 4F NET AREA: 38,007 SQUARE FEET OR 0.872 ACRES
LOT 4G NET AREA: 2,563,996 SQUARE FEET OR 58.86 ACRES
R/W DEDICATION: 40,469 SQUARE FEET OR 0.929 ACRES

NOTES:

- CONSTRUCTION WITHIN UTILITY EASEMENTS SHALL BE LIMITED TO UTILITIES, FENCES AND DRIVEWAYS.
- NO STRUCTURES OR VEGETATION OF ANY KIND THAT WOULD IMPEDE THE FLOW OF WATER THROUGH THE EASEMENTS MAY BE CONSTRUCTED, PLANTED OR ALLOWED TO GROW WITHIN DRAINAGE EASEMENTS.
- ONLY GROUND COVER AND BUSHES ARE ALLOWED TO BE PLANTED WITHIN EASEMENTS DEDICATED FOR THE EXCLUSIVE USE OF WATER, SANITARY SEWER, RECLAIMED WATER OR ANY COMBINATION THEREOF. NOTREES ARE ALLOWED.
- VISIBILITY EASEMENT RESTRICTIONS: ANY OBJECT, WALL, STRUCTURE, MOUND, OR LANDSCAPING (MATURE) OVER 24" IN HEIGHT IS NOT ALLOWED WITHIN THE VISIBILITY EASEMENT.
- RIGHT-OF-WAY LANDSCAPE SHALL BE THE MAINTENANCE RESPONSIBILITY OF THE ADJACENT PROPERTY OWNER OR THE HOMEOWNER'S ASSOCIATION.
- REPLACEMENT OF DEAD TREES ALONG ARTERIAL AND COLLECTOR STREETS SHALL BE BY THE INDIVIDUAL PROPERTY OWNER OR THE HOMEOWNER'S ASSOCIATION AND SHALL BE COMPLETED WITHIN THREE (3) MONTHS FROM THE DATE THAT THE ASSOCIATION OR PROPERTY OWNER IS NOTIFIED BY THE CITY.
- PROPERTY OWNER OR HOMEOWNER'S ASSOCIATION WILL ASSUME RESPONSIBILITY FOR THE MONTHLY OPERATING AND MAINTENANCE COSTS FOR ALL STREETLIGHTS WITHIN THE DEVELOPMENT AND ADJACENT ARTERIALS.

OWNER:

CITY OF MARICOPA
39700 W. CIVIC CENTER PLAZA
MARICOPA, ARIZONA 85138

CONTACT: REGIS REED
PHONE: (623) 256-3600
EMAIL: REGIS.REED@MARICOPA-AZ.GOV

ENGINEER:

3 ENGINEERING
6370 E. THOMAS ROAD, SUITE 200
SCOTTSDALE, ARIZONA 85251

CONTACT: DANEIL G. MANN, P.E.
PHONE: (602) 334-4387
EMAIL: DAN@3ENGINEERING.COM

ADDRESS:

UNASSIGNED
PORTION OF APN 502-03-012M,
MARICOPA, AZ, 85138

SURVEYOR:

3 ENGINEERING
6370 E. THOMAS ROAD, SUITE 200
SCOTTSDALE, ARIZONA 85251

CONTACT: JAMES A. LOFTIS
PHONE: (602) 334-4387

BASIS OF BEARING:

WEST LINE SOUTHWEST QUARTER SECTION 30,
T-4-S, R-4-E BEARS N00°18'48"E PER SURVEY
RECORDED IN FEE NO. 2022-115633

CERTIFICATIONS AND APPROVAL

APPROVED:

DEVELOPMENT SERVICES DIRECTOR
CITY OF MARICOPA, ARIZONA

APPROVED:

CITY ENGINEER DATE
CITY OF MARICOPA, ARIZONA

APPROVED BY THE COUNCIL OF THE CITY OF MARICOPA,
ARIZONA, THIS ____ DAY OF _____,
20 ____ .

BY: _____ MAYOR DATE

ATTEST: _____ CITY CLERK DATE

SURVEYORS CERTIFICATION:

THIS IS TO CERTIFY THAT THIS RE-PLAT IS CORRECT AND ACCURATE AND THE MONUMENTS DESCRIBED HEREIN HAVE EITHER BEEN SET OR LOCATED AS DESCRIBED TO THE BEST OF MY KNOWLEDGE AND BELIEF.

JAMES A. LOFTIS, R.L.S.
ARIZONA NO. 26404
6370 E. THOMAS ROAD, SUITE 200
SCOTTSDALE, ARIZONA 85251



MARICOPA CITY COMPLEX

FINAL PLAT

3engineering
civil engineering
surveying

3 ENGINEERING, LLC
6370 E. THOMAS ROAD
SUITE # 200
SCOTTSDALE, ARIZONA 85251
PHONE: (602) 334-4387
FAX: (602) 495-3220
WWW.3ENGINEERING.COM

DATE: 12/21/23

PROJECT NO.
2188

SHEET NO.
FP01
1 of 2

MARICOPA CITY COMPLEX

FINAL PLAT

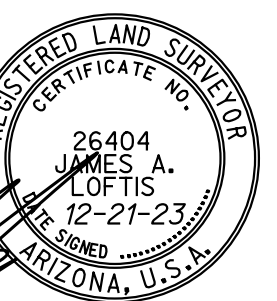

3eengineering
 planning civil engineering surveying
 3 ENGINEERING, LLC
 6370 E. THOMAS ROAD
 SUITE # 200
 SCOTTSDALE, ARIZONA 85251
 PHONE: (602) 334-4387
 FAX: (602) 495-3220
 WWW.3ENGINEERING.COM

DATE: 12/21/23
 PROJECT NO: 2188
 SHEET NO: FP02
 2 of 2

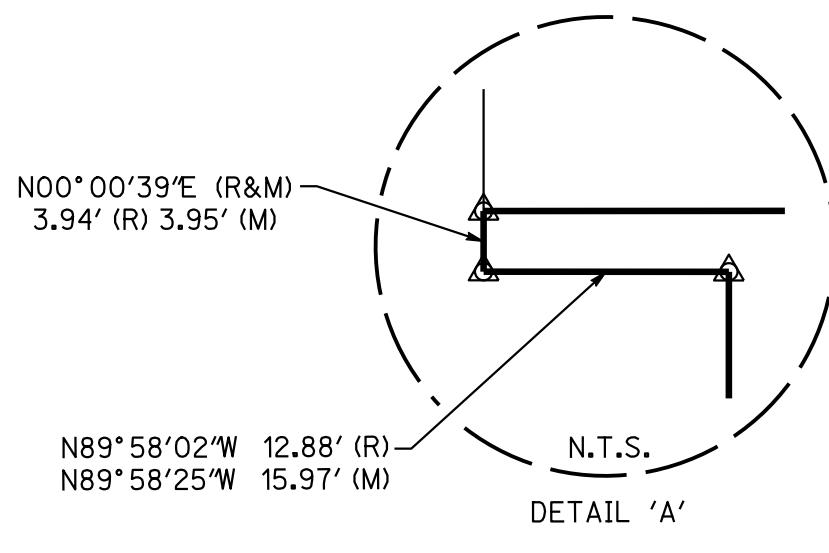
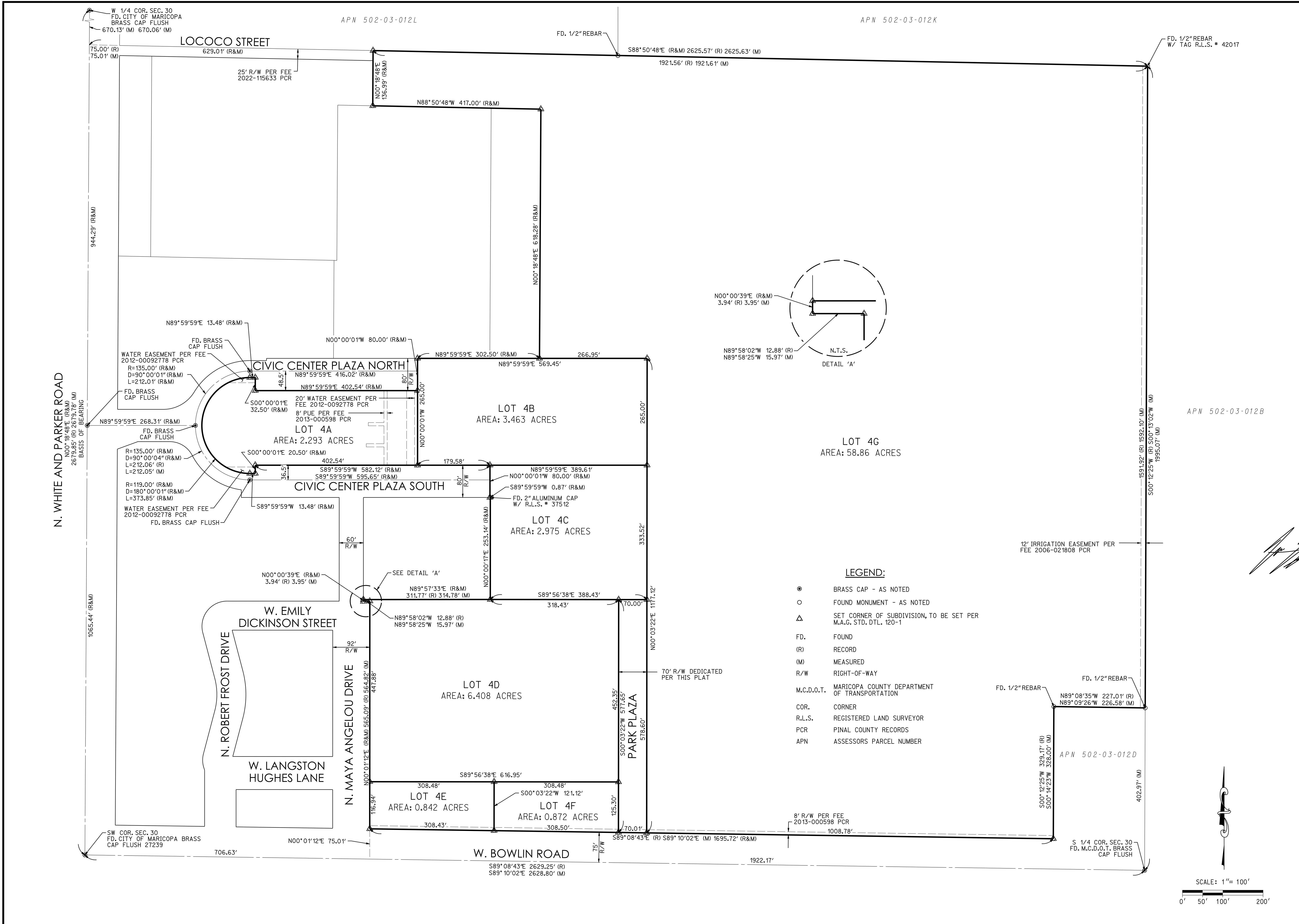

- LEGEND:**
- BRASS CAP - AS NOTED
 - FOUND MONUMENT - AS NOTED
 - △ SET CORNER OF SUBDIVISION, TO BE SET PER M.A.G. STD. DTL. 120-1
 - FD. FOUND
 - (R) RECORD
 - (M) MEASURED
 - R/W RIGHT-OF-WAY
 - M.C.D.O.T. MARICOPA COUNTY DEPARTMENT OF TRANSPORTATION
 - COR. CORNER
 - R.L.S. REGISTERED LAND SURVEYOR
 - PCR PINAL COUNTY RECORDS
 - APN ASSESSORS PARCEL NUMBER

